

EASILY CONFIGURED TO MEET YOUR NEEDS

FORK

- Load platform

POWER

- Standard winch

BASE

- Standard base

WHEEL / CASTER OPTIONS

- 8 in (20 cm) non-marking rear wheels
- Pneumatic 8 in (20 cm) rear wheels for rough terrain
- 2 in (5 cm) non-marking front swivel casters

OPTIONS & ACCESSORIES

PRODUCTIVITY

- 8 in (20 cm) non-marking rear wheels
- Pneumatic 8 in (20 cm) rear wheels for rough terrain
- 2 in (5 cm) non-marking front swivel casters
- Field-installable foot break

STANDARD FEATURES

MEASUREMENTS

- 5 ft 7 in (1.70 m) working height
- Up to 200 lb (91 kg) load capacity

PRODUCTIVITY

- Portable and compact design
- Lightweight durable aluminum construction
- High strength aircraft quality cable
- Cushioned neoprene hand grip
- Beveled aluminum platform for easy loading and unloading
- Portable - folds for compact storage
- 8 in (20 cm) performa non-marking rear wheels
- Stair glides for easy handling on stairs
- Hold-down mechanism secures for transport

POWER

- Standard quiet high-speed winch
- Reversible winch handle for easy storage



Specifications

MODEL	LOAD LIFTER™	
MEASUREMENTS	US	Metric
A Height - stowed	3 ft 9 in	1.14 m
Height - platform maximum	5 ft 7 in	1.70 m
B Length - stowed	1 ft 3 in	.38 m
Length - operating	2 ft 4.75 in	.73 m
C Width - stowed	1 ft 8.5 in	.52 m
PRODUCTIVITY		
Load capacity	200 lbs	91 kg
D Load height minimum	2 in	.05 m
Ground clearance - center	.75 in	.02 m
Average cranks - standard winch	3 cranks/ft	3 cranks/.30 m
E Load platform length	1 ft 2 in	.36 m
F Load platform width	1 ft 4.75 in	.43 m
POWER		
Power source	reversible standard winch	
WEIGHT*		
	45 lbs	20 kg

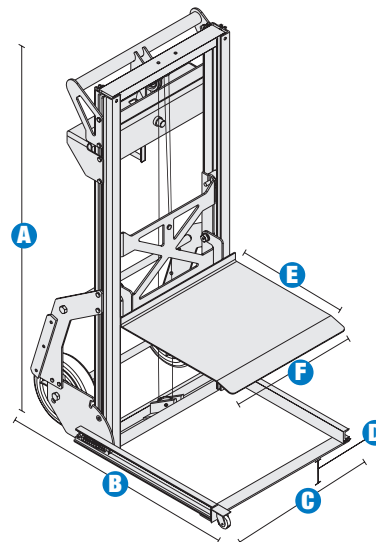

* Weight will vary depending on options and/or country standards.

Genie United States

18340 NE 76th Street
P.O. Box 97030
Redmond, Washington 98073-9730

Telephone **(425) 881-1800**
Toll Free in USA/Canada **800-536-1800**
Fax (425) 883-3475

Genie Europe

The Maltings
Wharf Road
Grantham NG31 6BH
U.K.

Telephone **+44 (0)1476 584333**
Fax +44 (0)1476 584334

Email: infoeurope@genieind.com

Distributed By:

For further information, please contact your local distributor or the Genie Industries sales office listed. Product specifications are subject to change without notice or obligation. The photographs and drawings in this brochure are for illustrative purposes only. Refer to the appropriate Operator's Manual for instructions on the proper use of this equipment. Failure to follow the appropriate Operator's Manual when using our equipment or to otherwise act irresponsibly may result in serious injury or death. Prices and specifications subject to change without notice. The only warranty applicable is the standard written warranty applicable to the particular product and sale. Genie makes no other warranty, expressed or implied. Products and services listed may be trademarks, service marks or trade-names of TEREX Corporation and/or its subsidiaries in the USA and other countries and all rights are reserved. Copyright © 2006 Genie Industries, Inc. "Genie" is a Registered Trademark of Genie Industries, Inc. in the USA and many other countries. Genie is a TEREX Company.